

LTU1 Horizontal Conveying Lifting Unit  
Instruction & Maintenance Manual  
LTU1 横向输送提升单元安装使用维护手册

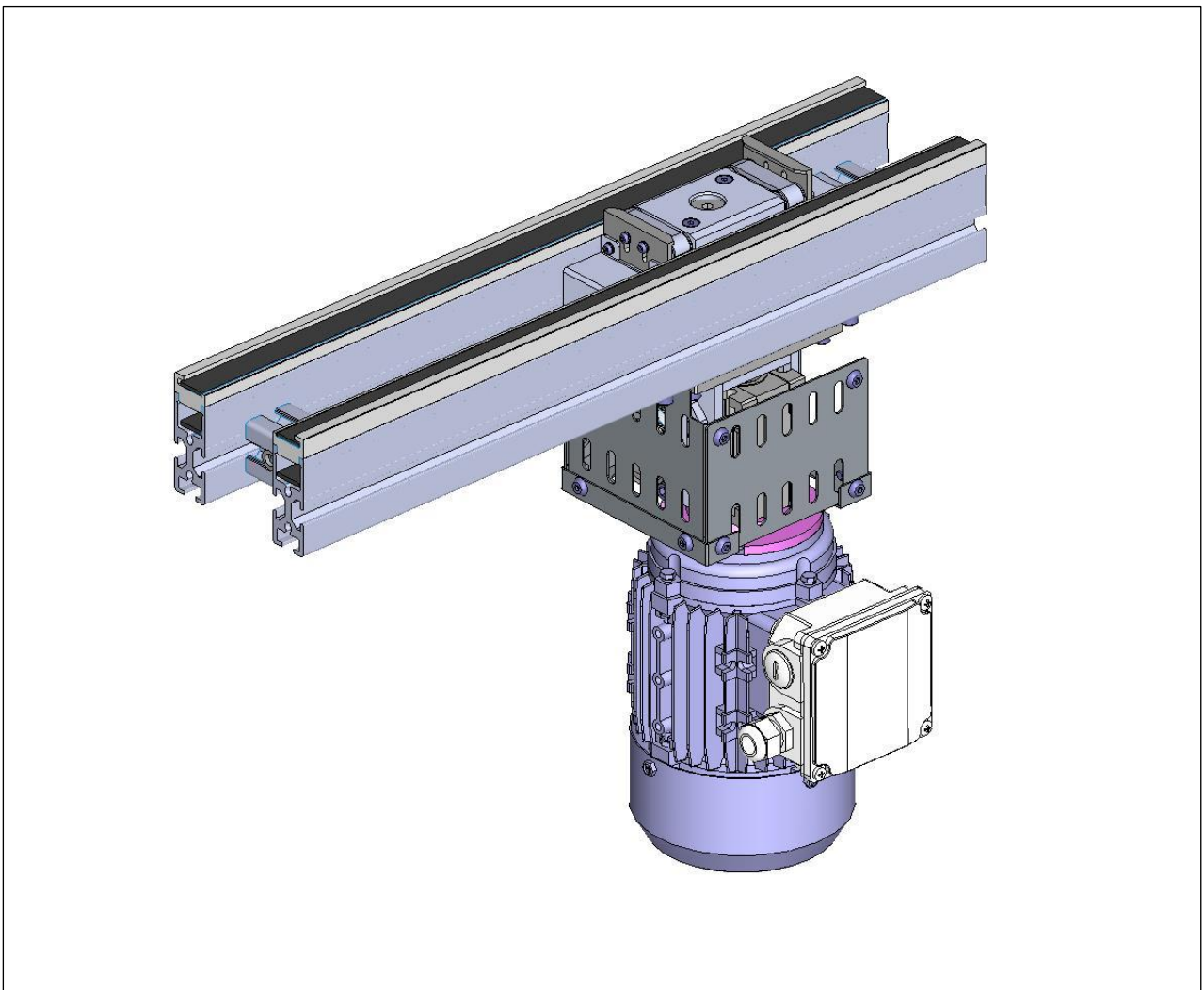

Suzhou LinkedGo Transfer System Co.,Ltd.

苏州领科工业技术有限公司

## Structure Diagram 结构示意图

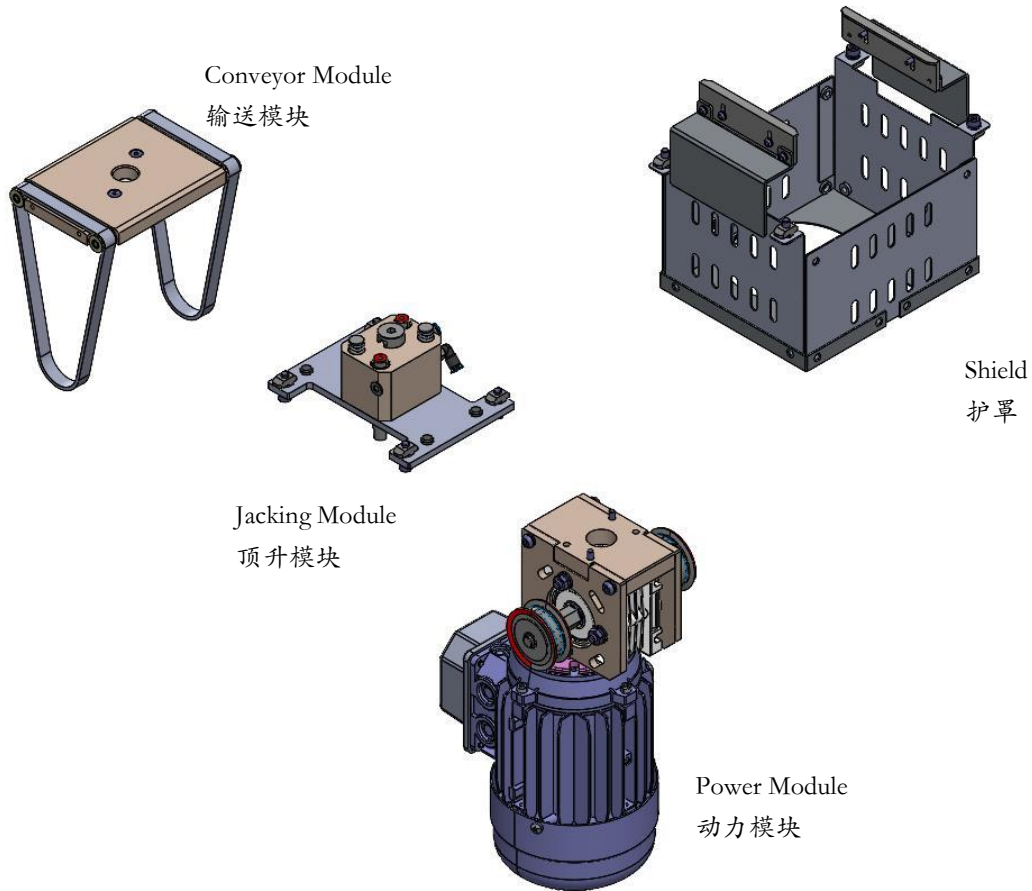

1. The LTU1/U type lateral conveying lifting unit is used to transport the workpiece tray from the longitudinal conveying section to the transverse conveying section, and vice versa.

1、LTU1/U 型横向输送提升单元用于将工件托盘从纵向输送段送到横向输送段，反之亦然。

2. The track width B for LTU1/U-shaped conveying direction is 80-160mm, which can be customized according to customer requirements.

2、LTU1/U 型输送方向的轨道宽度 B 为 80-160mm，可根据客户要求定制。

3. The maximum total load of the workpiece tray is 3kg.

3、工件托盘最大总负载 3kg。

4. Reversible operation.

4、可反转运行。

Model Description 型号说明

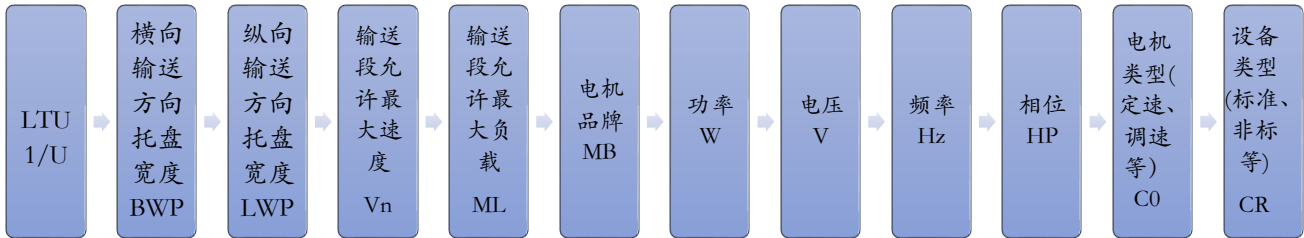

例：LTU1/U-Bwp80-Lwp80-Vn11-ML03kg,MB=Jonstar-90W-380V-50Hz-3HP-C0

The model LTU1/U-Bwp80-Lwp80-Vn11-ML03kg,MB=Jonstar-90W-380V-50Hz-3HP-C0 represents a fixed speed motor with a width of 80mm in the horizontal conveying direction and a length of 80mm in the vertical conveying direction. The maximum operating speed of the conveying section is 11m/min and the maximum operating load is 3kg. The motor brand is Jonstar, with a power of 90W, a voltage of 380V, a frequency of 50Hz, and a phase of 3.

型号 LTU1/U-Bwp80-Lwp80-Vn11-ML03kg,MB=Jonstar-90W-380V-50Hz-3HP-C0 表示横向输送方向托盘宽度 80mm, 纵向输送方向托盘长度 80mm, 输送段运行最大速度 11m/min, 运行最大负载 3kg, 电机品牌为 Jonstar, 功率为 90W, 电压为 380V, 频率为 50Hz, 相位为 3 的定速电机。

产  
品  
特  
征

安  
装  
步  
骤

维  
护  
保  
养

安装步骤 Installation steps

A Assemble the motor, cylinder, and reducer fixing plate.

A 组装电机、气缸、减速机固定板。

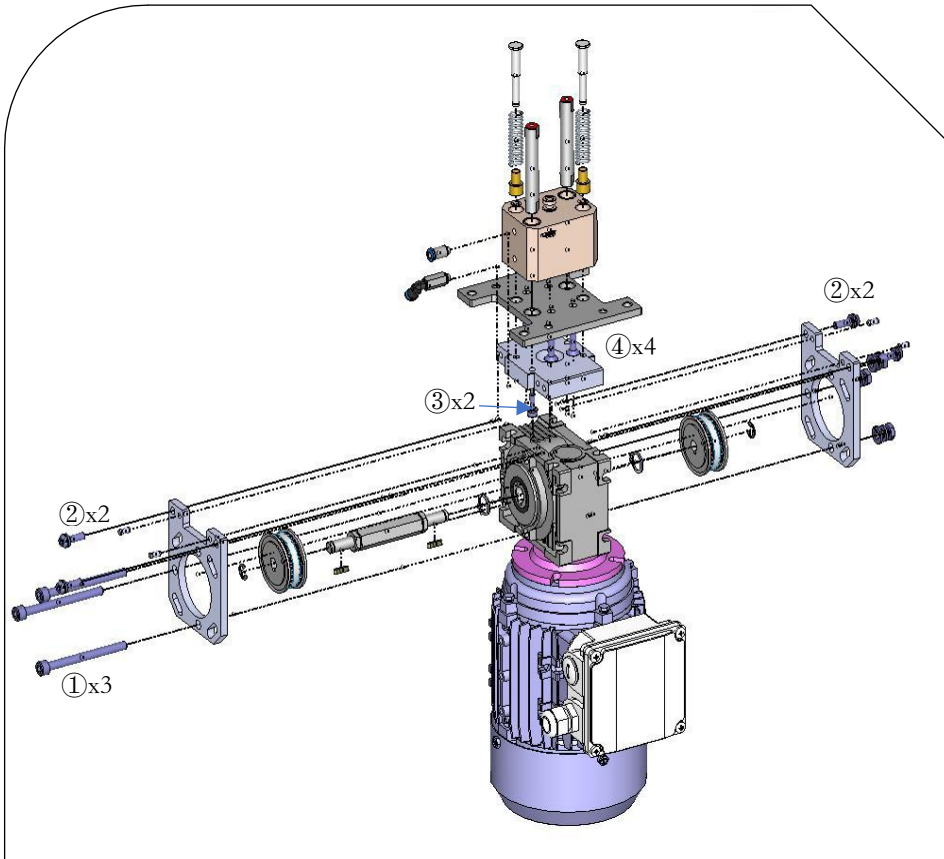

① — M6x65  
⑥ 13Nm

② — M5x16  
⑤ 8Nm

③ — M4x12  
④ 8Nm

④ — M5x16  
⑤ 8Nm

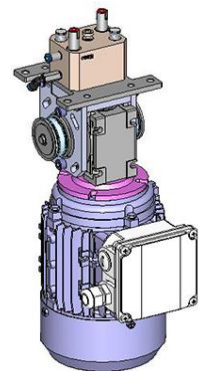

B Assemble the pneumatic module B.

B 组装气动模块。

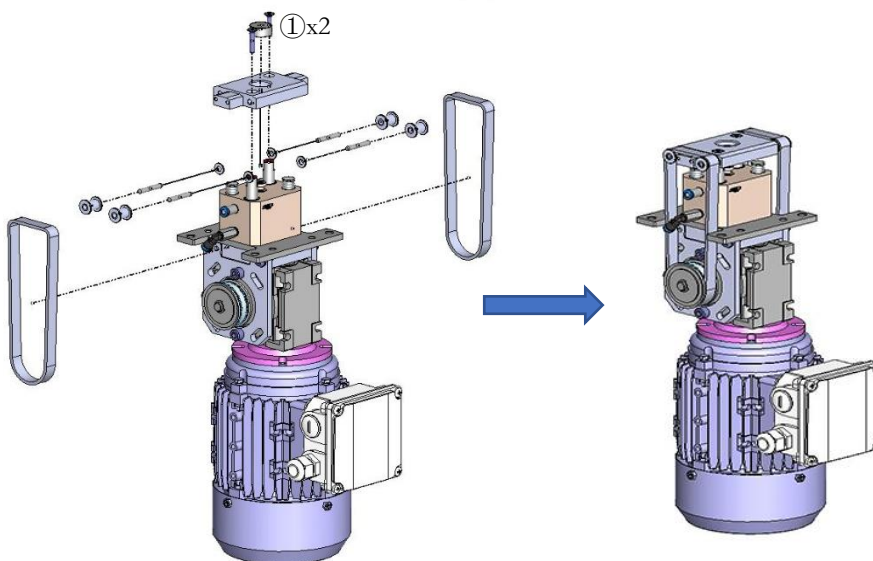

Attention: All small pulleys need to be filled with oil for installation (\* Do not fill with liquid oil!)

注意: 所有小皮带轮需注油安装 (\*请勿注液体油!)

① — M4x20  
④ 8Nm

C Install the cover.

C 安装护罩。

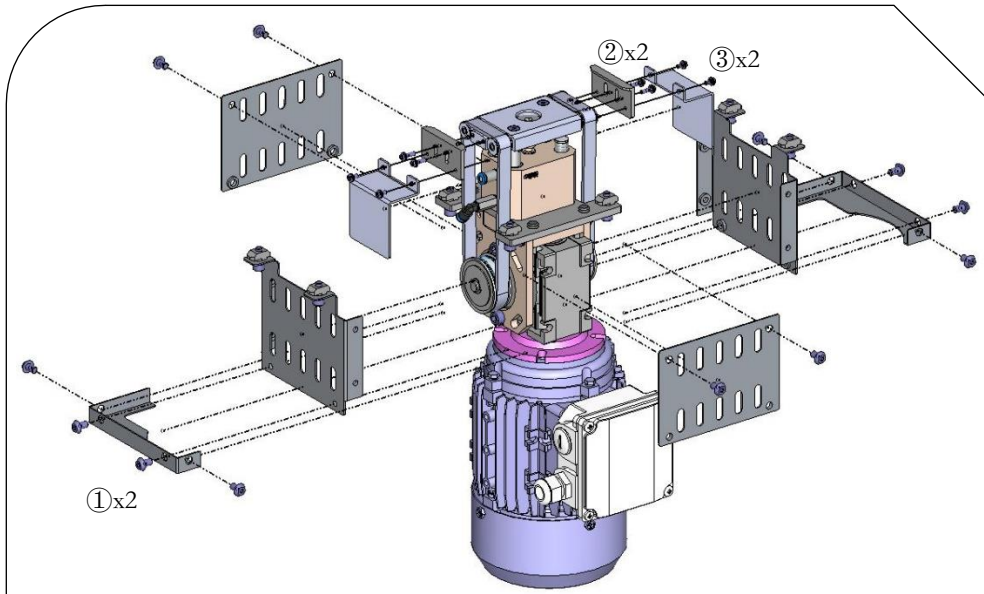

① — M5x8  
⑥ 6Nm

② — M3x10  
④ 6Nm

③ — M3x6  
④ 6Nm

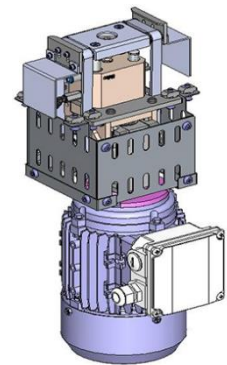

Attention: If installed on the wire body, some protective covers should not be installed temporarily, please refer to D for details!

注意：如果安装至线体上，则部分护罩暂不要安装，具体见D！

D Install to the wire body.

D 安装至线体。

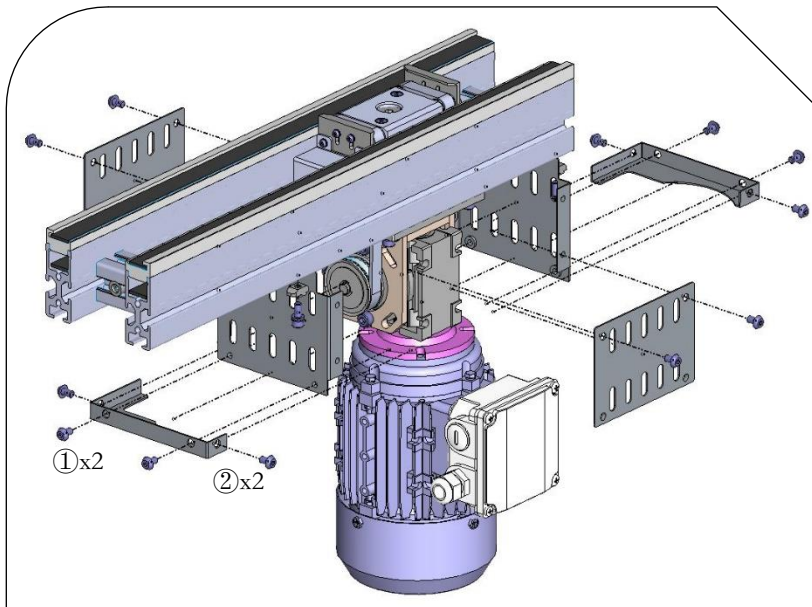

① — M5x8  
⑥ 6Nm

② — M5x12  
⑥ 6Nm

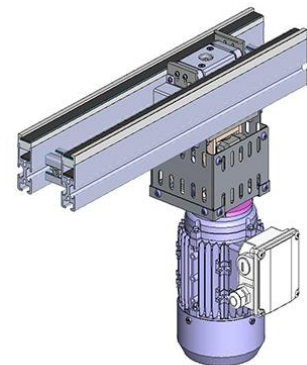

E Electric components, pneumatic components.

E 电动元件、气动元件。

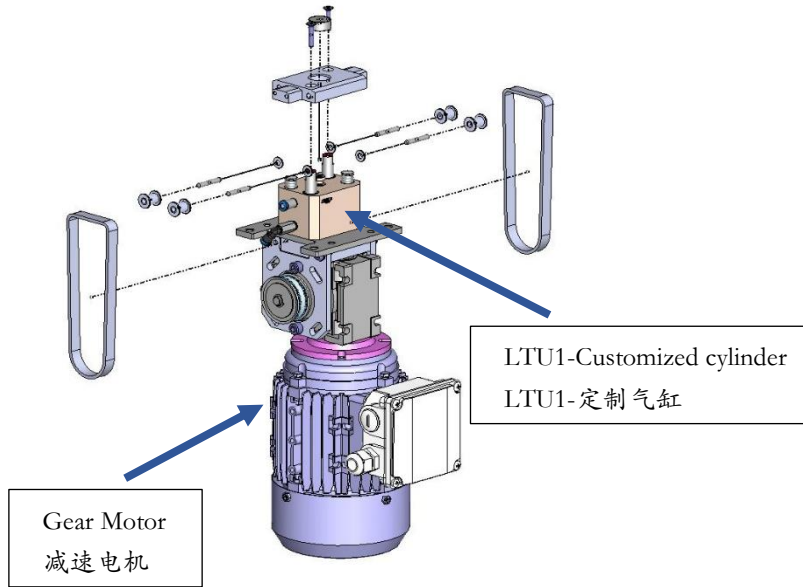

产品特征

安装步骤

维护保养

G Regular Troubleshooting.

G 常见故障及处理方法。

1. Motor overheating: Check if the equipment is operating under overload and if the motor wiring is loose.

1、电机过热：检查设备是否超载运作，电机接线是否松动。

Maintenance 维护和保养

The UTS series tray conveying system requires regular maintenance and upkeep to extend the service life of the line. The conveying equipment should be kept clean to avoid direct sunlight or rain or snow, and to prevent contact with substances such as acids, alkalis, oils, organic solvents, etc.

UTS 系列托盘输送系统需按周期进行规定的保养维护工作，以延长线体使用寿命。输送设备应保持清洁避免阳光直射或雨雪浸淋，防止与酸、碱、油类、有机溶剂等物质接触。维护前需关闭对应的能源供给。

1. Regularly wipe according to the usage environment. When wiping, soft cloth and towel should be used. It is strictly prohibited to use abrasive paper, wire brush, and other friction materials to wipe the surface of aluminum material. Warm water containing lubricants or neutral cleaning agents can be used for cleaning.

1、根据使用环境，定期擦拭。擦拭时需用软布、毛巾，严禁使用砂纸、钢丝刷等摩擦物擦洗铝材表面。可采用含润滑剂或中性清洗剂的温水清洗。

2. During packaging and transportation, it is strictly prohibited to loosen the bulk truck to cause scratches.

2、在包装运输过程中严禁松散装车，造成刮擦。

3. Regularly inspect vulnerable parts. Check if the fasteners are loose and tighten them in a timely manner.

3、定期检查易损件。检查紧固件是否松动，及时拧紧。

4. All small pulleys need to be filled with oil for installation (\* Do not fill with liquid oil!)

4、所有小皮带轮需定期注油。（\*请勿注液体油！）

Disclaimer

免责声明

The customer shall inspect the equipment regularly. If the customer fails to maintain the conveyor as the state above, leading to any malfunction or damage to the conveyor, our company will not be responsible for it, all related costs (including material costs, installation and commissioning fees, and hotel expense) shall be borne by the customer.

客户应定期对设备进行检查。若客户未按要求对输送机进行维护，进而导致输送机发生任何故障或损坏，我司将不承担相关责任，由此产生的相关费用（材料费，安装调试费，差旅费）均由客户承担。

Suzhou LinkedGo Transfer System Co.,Ltd.  
苏州领科工业技术有限公司

[Tel: +86-512-6636 1885](tel:+86-512-66361885)

Add: Room 706, Building D, Dongchuang Science and Technology Park,  
No. 216 Jinfeng Road, Wuzhong District, Suzhou, P.R. China

Zip code:215101

E-mail: [Sales@LinkedGo.com.cn](mailto:Sales@LinkedGo.com.cn)

Website: [www. LinkedGo.com.cn](http://www.LinkedList.com.cn)

Subject to technical modifications

电话：+86-512-6636 1885

地址：苏州市吴中区木渎镇金枫路 216 号东创科技园 D 幢 706 室

邮编：215101

邮箱：[Sales@LinkedGo.com.cn](mailto:Sales@LinkedGo.com.cn)

网址：[www.LinkedList.com.cn](http://www.LinkedList.com.cn)

我司保留技术更改的权利